

A. Abyzgildin, M. Abyzgildina

*Ufa State Petroleum Technical University*

**NEW INFORMATIONAL TECHNOLOGIES  
IN PROCESSING OF HYDROCARBON RAW MATERIAL.  
OUTLOOK TO THE 21<sup>ST</sup> CENTURY.**

The transmission of information is a very important element for the communication of people. When meeting each other, we exchange with information by means of a conversation. If relatives are at a great distance away from each other, they can phone, or, at least, write a letter. In the same way, a convenient means of the transmission of information is required to use in all spheres of life. If we wish the information were accessible only to a limited circle of persons, we can cipher it. Chinese or Japanese hieroglyphs do not require even ciphering - they are practically non-accessible to the most of people in the world.

If there are not enough words, special symbols are used for the transmission of information. Symbols are additional signs to the alphabet. The number of symbols may exceed even the number of letters in the alphabet. The most noticeable way of the information transmission is a note record of musical compositions. The information - a record by means of music symbols, located in a specific way on several lines - may be easily reproduced by a performer of any nationality.

Such useful minerals as oil, gas and coal are known to all of us. They are combustible useful minerals, which are main sources of thermal energy. If to take oil, then as a rule, it is not burnt up directly after its extraction out of bowels of the earth. Hydrocarbons in the composition of oil are initial raw material for receiving of many useful products. Even combs and synthetic shirts, not mentioning buttons, are products being received on the basis of hydrocarbons of oil. Unfortunately, instead of use of hydrocarbons for receiving products for a long use, most part of it is burnt up as automobile petrol, diesel fuels and reactive fuels. A heavy part of oil is burnt up in the furnaces of heating stations as a boiler fuel. For this purpose a solid and gaseous fuel is used, too.

To convert hydrocarbons of oil into this or that product, whether it is a fuel or a raw material of petrochemistry, it is necessary to have hundreds and thousands of apparatuses. Still, the apparatuses are connected with a large number of pipelines.

Imagine yourself a town erected according to such principle: firstly, houses are built (without any order, as it is done, for example, at cottage plots), and then, they start with laying of roads. It is possible to imagine how it would be difficult to move in such a labyrinth, especially for a newcomer. They say, that this is precisely such a picture in the suburb districts of Tokyo.

Unfortunately, somehow in this way, as described above, the information is represented about the interconnections of the technological apparatuses while describing oil-processing procedures. The discourse is about so-called flow process diagrams of the units at refineries (in abbreviation NPZ).

When describing a diagram, consisting of dozens of apparatuses, the situation is still endurable. But how to be in case of presence of hundreds of apparatuses in the dia-

gram? The diagram becomes resembling a ball of tangled threads; only a narrow circle of specialists is able to untangle it. To untangle, but not to remember! Practically, it is impossible to learn diagrams. But how to be with the archiving of diagrams, training of personnel, input of diagrams into computer? At present status, hundreds of square meters of paper are required to keep information about units. Despite this, a material drawn on paper is not easily understood for a quick comprehension.

This situation may be named as an information crisis. Attempts are made to go out of this crisis everywhere in the world. But everything comes to a simplification of diagrams by means of withdrawal of those apparatuses that unimportant from a viewpoint of the information transmitter, apparatus located at different levels, three-measured imprints and so on. This reminds a situation, when first attempts were made to invent a quick way of displacement. The century-old evolution of the living world brought living creatures to the moving ability by means of legs. Numerous inventions of means of movement with the help of some analogues of legs, i.e. copying of the alive world, did not bring to good results. But the invention of a wheel by man, the means, that was not created by the evolution of the living world, turned to be revolutionary for a decision of the problem of creation of means of the movement. As well as the above-mentioned, the creation of a new informational technology of processing of a hydrocarbon-content raw material, at which a team of scientists of the Petroleum University was working for dozens of years, was solved by rather an unusual way.

Traditionally, designers copied symbols of the apparatuses, literally, from model. If the discourse turned to a column, then this column was depicted on the diagram of a diminished scale. If it were a pump or a conveyer, then this pump was made in a miniature and the conveyer was depicted as a long tape. For hundreds of years dozens of columns were pictured on diagrams, the tie-in of which tangled all logic of the process performance rather quickly.

But what, if, firstly, to draw flow process streams (and without apparatuses they are rather simple combinations of lines - they are named graphs in special literature), and then, to place apparatuses on the received lines, without infringing logic? They need to be modified! It turned to be that two small geometric figures (circle, triangular) are sufficient for the designation of all apparatuses. Just recollect in mind the geographic map - circles of various sizes designate towns. A small dash across the line shall indicate the presence of a heat-exchanging apparatus.

If before, firstly, linen was hang on an imaginary clothes-line, and then, later on, the rope itself was stretched (this social example seems absurd), then, now, everything takes one's stand. Firstly, we stretch a rope (we draw flow process streams), then we hang on linen (place apparatuses on lines). The apparatus symbols like beads are threaded on lines, and a quickly recognized graphic model is received. As well as thousands of mammals have their own specific quickly-recognized shape, thousands of units get their own, a quickly recognized graphic image. You may be sure yourself, that even a two-year old child will recognize quickly the elephant per its pictured contour. An engineer-technologist shall not be able to define at a trivial image, a diagram of what kind of process is depicted on the drawings lying in front of him. Some time shall require for thinking over.

It happens so, that in practice a solution shall be taken immediately. This is just the case, when graphic models render an incalculable service.

Recollect in mind a scheme of the underground - the information included in the scheme is so simple, that even a Negro old woman is able to find out the way from point A to the point B, provided these points are marked to her on this scheme.

The diagram, including hundreds of apparatuses, can be placed rather easily on the computer screen, provided it is depicted in semblance of a graphic model.

The analysis of flow process diagrams of oil processing procedures showed that all their variety has only two types of graphic models.

Chemical processes are depicted as a circle with two tangent lines (drw.1). The recycle stock (for ex. hydrogen) in point 1 is combined with the initial raw material. In point 2, the re-cycled product is separated from the reaction products.

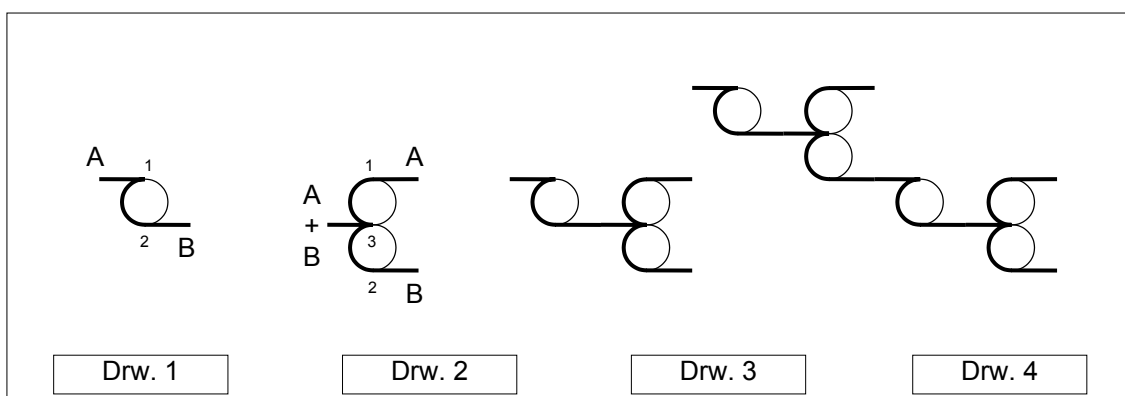

Physical processes, for example, the rectification of steams/liquid mixtures is depicted as 2-adjointing circles with three tangent lines (drw.2). A separation of steam and liquid mixture takes place in point 3, in point 1 - a part of product A is branched off for the evaporation as a liquid irrigation. In point 2, a part of product  $\hat{A}$  is stripped with the purpose of vapor irrigation. The only thing to do is to locate the apparatuses on streams. In order not to break the model design, we shall use simple symbols of the apparatuses, which can be easily located on the lines: circles of various diameters and various circumferences for reactors, columns, vessels, separators; the triangular - for pumps, compressors, conveyers, air-blowers; dashes across lines - for apparatuses of heat exchange. The diagram of a simple flow process unit consists of the reaction section and the section of the separation of the products of the reaction. Such a scheme is received by means of the combination of the models of types 1 and 2 (drw.3). As a rule, the product after the 1st stage of the separation is subject to secondary chemical conversions. In this case the process model is created by means of successive combination of models 1 and 2 (drw.4).

The complex plant of aromatic hydrocarbons production (JCS "Ufaneftekhim") consists of more than dozens of elementary graphic models (drw.5). The graphic model of the unit of the production of high-octane components of petrols, combining processes of hydro-treatment, reforming and isomerization (L-53-11/1000, JSC "Novo-Ufimski NPZ") is shown in drawing 6.

The graphic model of the heavy gas oil-processing unit with the production of petrol, propane-propylene and butane-butylene fractions (G-43-107, JSC "Ufimski NPZ") is shown in drw.7.

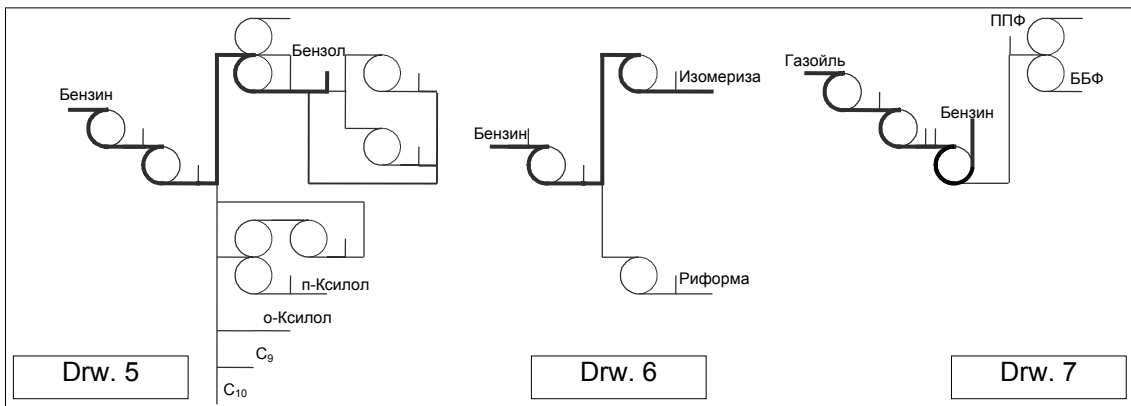

Evidently, graphic models of the most complicated units and complexes have a comparatively simple design structure, convenient for study and learning. Next stage, while designing a model, is placing of symbols of the apparatuses. An example of the model of the real process - the hydro-treatment section of unit L-35-11/1000 is shown in drawing 8. All information from the technical documentation available is transferred to

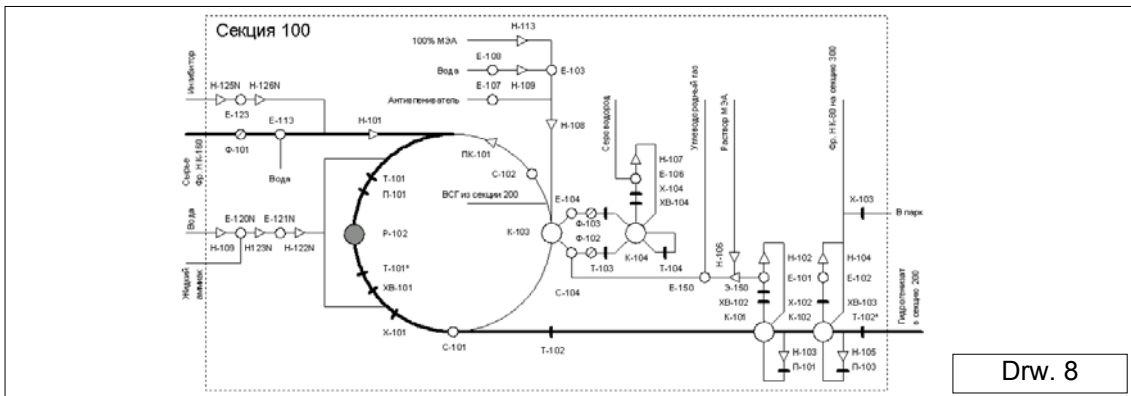

the given model (drw.9). The application of this technical documentation for every-day usage is difficult to imagine, meanwhile, it takes some seconds to receive any information, included in the operating model.

